

A SOFTWARE FOR PREDICTION OF PERIODIC RESPONSE OF NON-LINEAR MULTI DEGREE OF FREEDOM ROTORS BASED ON HARMONIC BALANCES

Mohammad Ali Rezvani

Abstract: *It is the purpose of this paper to introduce a computer software that is developed for the analysis of general multi degree of freedom rotor bearing systems with non-linear support elements. A numerical-analytical method for the prediction of steady state periodic response of large order nonlinear rotor dynamic systems is addressed which is based on the harmonic balance technique. By utilizing harmonic balance with appropriate condensation, it is possible to considerably reduce the number of simultaneous nonlinear equations inherent to this approach. Using this method, the set of nonlinear differential equations governing the motion of the rotor systems is transformed to a set of nonlinear algebraic equations. A condensation technique is also used to reduce the nonlinear algebraic equations to those only related to the physical coordinates associated with nonlinear components. The stability (linear) of the equilibrium solutions may be conveniently evaluated using Floquet theory, particularly if the damper force components are evaluated in fixed, rather than rotating, reference frames. The versatility of this technique is illustrated on systems of increasing complexity with and without damper centralizing springs.*

Keywords: *Rotor dynamics, fluid film bearings, inherent non-linearity, harmonic balance method, system reduction*

1. Introduction

The study of the motion of rotating machinery, i.e. rotor-dynamics, has long been an important field of engineering research. Rotors are found in a wide range of applications ranging from those found in large scale machinery used in the power generation industry to tiny rotors used in medical equipment. Rotating machinery generally consists of flexible shafts on support systems rolling element bearings, fluid film bearings, seals, etc.

The application of squeeze film dampers are commonly found in aircraft gas turbine engines, whereby these dampers provide additional external damping to the rotor bearing system for the purpose of reducing the synchronous response of the rotor especially while traversing critical speeds. There are two basic configurations of these dampers, which are the dampers with retainer springs and those without retainer springs. They differ in the way the rotor finds its position in the damper clearance space. In the damper without retainer spring, the journal that usually

lies at the bottom of the clearance space when the rotor is at rest, is lifted when sufficient imbalance is generated during running conditions of the rotor. In the damper with retainer spring, the journal is fitted with a spring, which often takes the form of a thin ribbed cylinder known as a squirrel cage. The retainer spring is fixed, at one end, to the dampers journal, whilst the other end is fixed to the damper's housing. A centralizing mechanism is occasionally used in conjunction with the retainer spring for the purpose of centring the journal in the damper clearance space. The stability and imbalance response of a flexible rotor mounted in centrally preloaded squeeze film dampers has been theoretically and experimentally investigated [1,2], whereby bistable operation of the rotor was found at certain values of design and operating parameters. Nikolajsen and Holmes [3] observed non-synchronous whirl orbits in the experimental response of a flexible rotor supported by journal bearings in series with squeeze film dampers with retainer springs. The effect of fluid inertia for cavitating dampers operating at moderately large squeeze film Reynolds number has been theoretically observed by San Andres and Vance [4] to possibly reduce or totally eliminate bistable operation and jump phenomena in the response of a flexible rotor mounted in centrally preloaded

Paper first received May. 10, 2007 and in revised form July, 05, 2009.

Mohammad Ali Rezvani, School of Railway Engineering, Iran University of Science and Technology, Tehran, Iran.
rezvani@mail.iust.ac.ir

squeeze film dampers. Zhao [5] has shown the occurrence of jump phenomena and quasi-periodic motion in the concentric operation of squeeze film dampers supported flexible rotor. For eccentric operation of the damper, sub synchronous motion was also observed in addition to the jump phenomena and quasi periodic motion. In a paper by Ramesh and Kirk [6] the non linear response of a flexible rotor in eccentrically operated squeeze film dampers with centring springs was compared to the rotor response assuming a centrally preloaded damper. The centrally preloaded damper assumption, which gives synchronous circular rotor motions, had often been used in the study of rotor response due to computational simplicity as compared to the non linear damper model.

In the actual running condition of a rotor, the damper does not remain in a centred position but tends to find its own eccentric position. The response resulting from the non linear model can be significantly different than that resulting from the centralized damper assumption. In the response of a flexible rotor in squeeze film dampers without retainer springs, theoretically investigated by Cookson and Kossa [7], it was found that for poorly designed dampers, the maximum force transmitted to the bearing support can be significantly greater than would have been the case if the dampers were not fitted. The occurrence of quasi periodic vibrations has been observed by Rezvani and Hahn [8] in the experimental response of a flexible rotor in squeeze film dampers without retainer springs.

For dampers which are not centrally preloaded, the steady state journal centre orbit need not be circular and its determination generally necessitates transient solutions [7]. It is often computationally prohibitive to carry out parametric design studies on the vibration behaviour of such rotor bearing systems, and various attempts have been made to quasi-linearize the damper forces [9]. Such solutions assume that the journal centre motions are synchronous with the excitation frequency and make no allowance for the possibility of sub and super-harmonic vibrations. Trigonometric collocation and harmonic balance techniques have been successfully tried over a limited range of relevant parameters [10] for rigid rotors. Extension to general rotor bearing systems necessitates a condensation of the potentially large number of nonlinear simultaneous equations to a manageable size, and the technique to be used for determining equilibrium orbits in this report is similar to that in [11], except that recourse to complex numbers is avoided. As evidenced by the unexpected instabilities discovered in [12], stability evaluation of equilibrium orbits is an essential requirement of assumed equilibrium solution analyses. Since the perturbed orbits may now result in linear differential equations with periodic coefficients even with rotating coordinates, the theory is developed with the damper forces expressed directly in terms of stationary coordinates, thereby simplifying the application of

Floquet theory [13,14] in evaluating system stability. The versatility of the technique is illustrated on systems with and without centralizing springs and of increasing complexity. Of particular interest, is the applicability of this approach to unsupported systems with relative large unidirectional loadings, i.e., at high orbit eccentricities as occurs when the damper has just lifted off, as well as to the confirmation of the instability results reported in [12].

2. Theoretical Model

2-1. Mathematical Development

The equations of motion of a rotor dynamic system with the assemblage of rigid disks, flexible rotor shaft, bearings, and supports can be modelled with the following procedure.

Consider an r -degree of freedom rotor bearing system, with nonlinear forces associated with q of these degrees of freedoms running in one or more squeeze film damped flexible supports. The multi-mass flexible rotor in Fig. 1 is an example of such a system wherein highly nonlinear damper forces exist at each damper location.

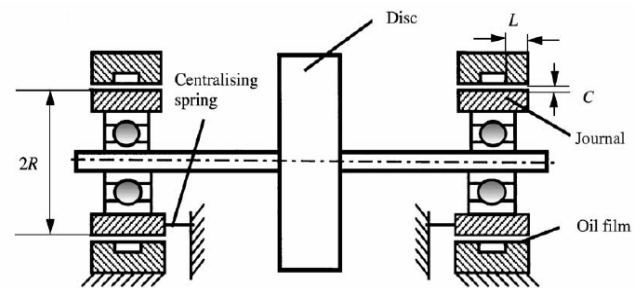

Fig. 1. Schematic of a flexible rotor bearing system

One can write the equations of motion as :

$$M\ddot{X} + C\dot{X} + KX = F \quad (1)$$

where the first p equations do not involve non-linear motion dependant forces.

$$\text{i.e., } p = r - q. \quad (2)$$

If steady-state conditions have been reached, with the system being subjected to a periodic excitation force of frequency ω , such as unbalance excitation, one can assume that the equilibrium or steady state solutions are of the form:

$$X_E = A_0 + \sum_{k=1}^n (A_k \cos \lambda_k t + B_k \sin \lambda_k t) \quad (3)$$

Where

$$\lambda_k = k\omega / N = k\Omega \quad (4)$$

and it is assumed that there are n harmonics of the fundamental frequency Ω . Required are the $(2n+1)$

coefficients $A_0, A_1, \dots, A_n, B_1, \dots, B_n$ which are to be found by harmonic balance. Thus,

$$\dot{X}_E = -\sum_{k=1}^n \lambda_k (A_k \sin \lambda_k t - B_k \cos \lambda_k t) \quad (5)$$

And

$$\ddot{X}_E = -\sum_{k=1}^n \lambda_k^2 (A_k \cos \lambda_k t + B_k \sin \lambda_k t) \quad (6)$$

and Eq.(1) becomes:

$$M\ddot{X}_E + C\dot{X}_E + KX_E = F_E \quad (7)$$

where

$$F_E = C_0 + \sum_{k=1}^n (C_k \cos \lambda_k t + S_k \sin \lambda_k t) \quad (8)$$

The Fourier coefficients of F_E , viz. C_0, C_k and S_k are functions of the X_E , the \dot{X}_E , and the external excitation.

Hence, on substituting Eqs.(3), (5) and (8) into Eq.(7) and equating coefficients for the constant terms, one obtains:

$$KA_0 = C_0 \quad (9)$$

or, in partitioned form:

$$\begin{bmatrix} K_{pp} & K_{pq} \\ K_{qp} & K_{qq} \end{bmatrix} \begin{bmatrix} A_0^p \\ A_0^q \end{bmatrix} = \begin{bmatrix} C_0^p \\ C_0^q \end{bmatrix} \quad (10)$$

where K_{pq} is a matrix of order $p \times q$ and C_0^p is a vector of order p .

By eliminating the A_0^p from Eq.(10) one obtains:

$$\left[K_{qq} - K_{qp} K_{pp}^{-1} K_{pq} \right] A_0^q + K_{qp} K_{pp}^{-1} C_0^p = C_0^q \quad (11)$$

Equation (11) is a set of q nonlinear simultaneous equations in the $(2n+1) q$ unknowns $A_0^q, A_1^q, \dots, A_n^q, B_1^q, \dots, B_n^q$ which determine the C_0^q . Note that in the absence of linear spring forces, $K=0$, and the left hand side of Eq.(11) is then zero.

Again, on equating coefficients for the cosine terms, for each k th harmonic, one obtains:

$$\left[K - \lambda_k^2 M \right] A_k + \lambda_k C B_k = C_k \quad (12)$$

or

$$Q A_k + R B_k = C_k \quad (13)$$

Similarly, on equating coefficients for the sine terms, for each k th harmonic, one obtains:

$$Q B_k - R A_k = S_k \quad (14)$$

Elimination of A_k from Eqs.(13) and (14), by pre-multiplying Eq.(13) by Q^{-1} and substituting into Eq.(14) gives:

$$\left[Q + R Q^{-1} R \right] B_k = S_k + R Q^{-1} C_k \quad (15)$$

Or

$$T B_k = W \quad (16)$$

In partitioned form:

$$\begin{bmatrix} T_{pp} & T_{pq} \\ T_{qp} & T_{qq} \end{bmatrix} \begin{bmatrix} B_k^p \\ B_k^q \end{bmatrix} = \begin{bmatrix} W^p \\ W^q \end{bmatrix} \quad (17)$$

Note that the W^p and the W^q are functions of X_E and \dot{X}_E . Elimination of B_k^p from Eq.(17) gives:

$$\left[T_{qq} - T_{qp} T_{pp}^{-1} T_{pq} \right] B_k^q + T_{qp} T_{pp}^{-1} W^p = W^q \quad (18)$$

Equation (18) constitutes a further set of nq nonlinear simultaneous equations in the $(2n+1)q$ unknowns.

Again, elimination of B_k from Eqs.(13) and (14) by pre-multiplying Eq.(14) by Q^{-1} and substituting into Eqs.(13) gives:

$$T A_k = C_k - R Q^{-1} S_k = V \quad (19)$$

Partitioning as was done before to obtain Eq.(17) from (16), one can solve for the A_k^q to obtain:

$$\left[T_{qq} - T_{qp} T_{pp}^{-1} T_{pq} \right] A_k^q + T_{qp} T_{pp}^{-1} V^p = V^q \quad (20)$$

where again the V^p and V^q are functions of the X_E and \dot{X}_E . Equation (20) constitutes yet another set of nq nonlinear simultaneous equations in the $(2n+1)q$ unknowns. Hence, together with Eqs.(11) and (18), one has a set of $(2n+1)q$ nonlinear simultaneous equations in the $(2n+1)q$ unknowns $A_0^q, A_1^q, \dots, A_n^q, B_1^q, \dots, B_n^q$.

These equations need to be solved by some iterative procedure, such as Newton - Raphson which is the procedure adopted in this report. Convergence is assumed when changes in successive values of the unknowns are less than 0.0001C. Significant values for the amplitudes of the highest assumed harmonics indicate the need for including additional harmonics,

and such further addition of harmonics continues till there is no significant change in the lower harmonic values. Once found, the remaining $(2n+1)p$ unknowns, $A_0^p, A_1^p, \dots, A_n^p, B_1^q, \dots, B_n^q$ can be found from the now simultaneous linear sets of equations obtained by eliminating the A_0^q from Eqs.(10), B_k^q from Eqs.(17) and A_k^q from Eqs.(19).

Note that no matter how many degrees of freedom there are in the system, the number of nonlinear simultaneous equations to be solved is still only $(2n+1)q$. In general, each damper introduces nonlinear forces into four equations of motion, reducing to two equations when the damper connects to ground. Thus, $q = 4$ or 2 for a system with one damper only, whereas r could be a number of any value. Also, for physical systems, Q^{-1} and T_{pp}^{-1} always exist, so the only computational problem is that generally associated with numerical iterative schemes, viz. convergence to all possible solutions. The other potential disadvantage of this approach is the initial choice of the fundamental frequency. Subharmonic solutions (solutions with frequency components lower than the lowest excitation frequency) are occasionally possible. These are catered

for by assuming a fundamental frequency of $\Omega = \omega/N$ where N is assumed to be an integer. However, there is no sure way of knowing whether all possible values on N have been exhausted as multi-equilibrium solutions of the same or of different fundamental frequencies to the excitation frequency are occasionally possible.

2-2. Fluid Film Forces

The above theory is developed quite generally and may be applied to any system with nonlinear motion dependent forces. The illustrative examples in this report involve the nonlinear forces arising with end feed squeeze film dampers [15]. It is assumed that the fluid is Newtonian with constant properties at some mean temperature, the flow is laminar, the fluid inertia forces are negligible, there is no slip at the bearing surfaces, h/L is of order 10^{-3} , the short bearing approximation is applicable (valid provided $L/D < 0.25$, [15]), and there is no variation in the film thickness in the axial direction. The momentum and continuity equations for the damper fluid then result in the simplified Reynolds equation [16] viz:

The fluid film force components are then given by:

$$\begin{Bmatrix} F_y \\ F_z \end{Bmatrix} = -\mu RL^3 \int_{\psi^*}^{\psi^*+\pi} \frac{(y \cos \psi + z \sin \psi)}{(C - z \sin \psi - y \cos \psi)^3} \begin{Bmatrix} \cos \psi \\ \sin \psi \end{Bmatrix} d\psi \quad (21)$$

3. Computer Program

Following the basic theory presented in this article a computer program for dynamic analysis (HBA) of general squeeze film damped multi-degree of freedom rotor bearing systems based on the harmonic balance method is developed.

3-1. Program Flow Chart

Flow of programs for harmonic balance analysis of general squeeze film damped multi-degree of freedom rotor bearing systems, program HBA, is given in Fig. 2.

3-2. Program Input / Output

Elements of mass, damping and stiffness matrices are initialized with zeros in the main program. As a result, user needs to fill in nonzero elements only. Constant terms in forcing functions assumed to correspond to gravity. For those freedoms required, user introduces amounts of masses only. Cosine and sine terms of forcing functions assumed to rise from the presence of unbalance masses. Squeeze film damper parameters including oil viscosity, radial clearance, radius, length, and number of squeeze film dampers should also be

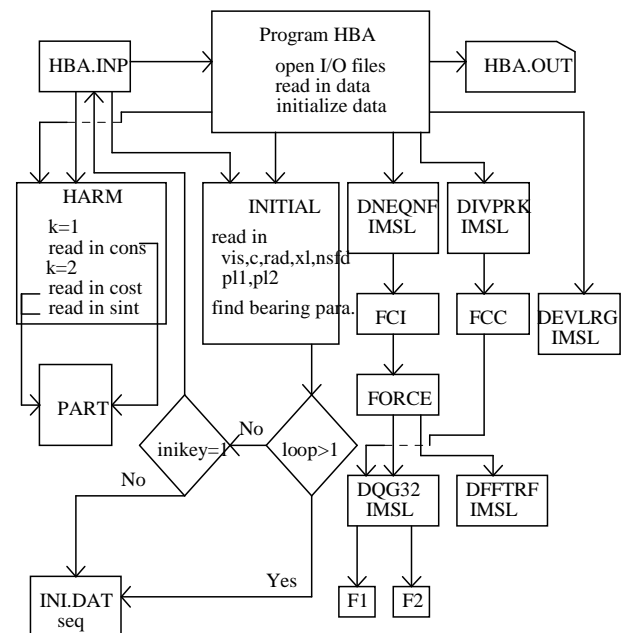

Fig. 2. Flow chart of Harmonic Balance Analysis program (HBA)

given as input data. Preload assumed to be effective on damper vertical freedoms, also affected by gravity. Initial guesses are essential for harmonic balance solutions. This program can find its initial guesses

from two sources namely from data available in an input file or by rewinding temporary output file and reading last stage data as initial data for the next stage. Output from this program includes information about the system including total degrees of freedom, number of linear and nonlinear freedoms, level of sub-harmonics included, number of Fourier terms used and rotor frequency. Mass, damping and stiffness matrices plus damper specifications together with the amount of preloads on damper freedoms are also included. Displacement of damper inner and outer freedoms, corresponding absolute eccentricities, eccentricity of inner ring relative to outer ring and stability analysis data in form of eigenvalues are also part of output data.

3-3. The Main Program

Purpose of the main program is to open input/output files, initialize data, set system equations of motion according to input data, initialize solver subroutines and print out the results. The corresponding sub-programs include;

- HARM - INITIAL - PART - FCI
- FCC - FORCE - F1 - F2 - DQG32
- DNEQNF - DLINRG - DMRRRR
- DIVPRK - DEVLRG - DFFTRF

3-4. Brief Description of Sub-Programs

Within this computer software, the main program “HARM” calls in 15 subprograms to perform different numerical tasks. A brief description about individual subprograms is given in this section. The required programming syntaxes corresponding to these subprograms are provided in Table 1.

Tab. 1. The required program syntax for all subprograms called in by program HARM

	Program	Syntax to call
1	HARM	HARM(amp, cpp, akpp)
2	PART	PART(la, lb, a, b, c, nr, np, nq, k, f, fl, g, gl, y, wl)
3	INITIAL	INITIAL(seq, loop)
4	FCI	FCI(seq, f, mm)
5	FORCE	FORCE(seq, cc)
6	F1, F2	F1(x), F2(x)
7	DQG32	DQG32
8	FCC	FCC(nr2, t, q, qprime)
9	DNEQNF	DNEQNF (fcn, errrel, n, itmax, xguess, x, fnorm)
10	DLINRG	DLINRG (n, a, lda, ainv, ldainv)
11	DMRRRR	DMRRRR(nra, nca, a, lda, nrb, ncb, b, ldb, nrc, ncc, c, ldc)
12	DIVPRK	DIVPRK (ido,n,fcn, t, tend, tol, param, y)
13	DEVLRG	DEVLRG (n, a, lda, eval)
14	DFFTRF	DFFTRF (n, seq, coef)

Subprogram “HARM”

The purpose of this subroutine is to build the idealized system equations of motion based on input data. System mass, damping, and stiffness matrices are input

to this program. It then reads in all the terms, including constant terms and unbalance terms, in forcing functions. Subroutine PART is then called in twice, to reduce degrees of freedom to that corresponding to the number of non-linear equations. Other parts of program HBA have access to output from program HARM through common statements.

Subprogram “PART”

The task of subroutine PART is to reduce the degrees of freedom to that corresponding to the number of non-linear equations. It is a general partition routine with nr, np, and nq defined in the calling program for the matrix a(la, la) and with k having either the value of 1 or 2. When option 1 is specified, it is used for the k-matrix. Option 2 is to partition the s-matrix (General theory).

Subprogram “INITIAL”

The purpose of this subroutine is to read in squeeze film damper parameters, amount of preload on damper freedoms and initial guessed solutions (seq). Damper parameters include oil viscosity, clearance, radius, length and number of dampers involved. It then calculates bearing parameter. Initial guess values can be supplied by the user in input file or program reads in ‘seq’ from last solutions. When parameter ‘loop’ is in use, program reads in ‘seq’ from input file for loop=1, otherwise it rewinds file ‘INI.DAT’ to update initial solutions.

Subprogram “FCI”

Subroutine FCI is a general routine setting up the system of nonlinear equations. From displacements specified in ‘seq’, subroutine FORCE is called to evaluate the forces in the x and y directions and return them as Fourier components. Subroutine FCI introduces the idealized system to IMSL subroutine DNEQNF.

Subprogram “FORCE”

The purpose of this subroutine is to evaluate the force terms arising from squeeze film dampers. From displacements specified in “seq”, subroutine FORCE is called to evaluate the forces in the x and y directions and return them as Fourier components in the vector cc.

Subprograms F1 and F2

For a given displacement y and z, and velocities dy and dz, functions F1 and F2 are called to give the damper forces acting in the y and z directions respectively at a particular angular position x.

Subprogram DQG32

This is a 32-order numerical quadrature integration subroutine. It is called by subroutine FORCE to perform squeeze film damper force calculations.

Subprogram “FCC”

Subroutine FCC is a general routine setting up the system of linear equations. FCC introduces the idealized system to subroutine DIVPRK.

Subprogram “DNEQNF”

This subprogram solves a system of nonlinear equations using a modified Powell hybrid algorithm and a finite-difference approximation to the Jacobian.

Subprogram “DLINRG”

This subprogram computes the inverse of a real general matrix.

Subprogram “DMRRRR”

This subprogram multiplies two real rectangular matrices.

Subprogram “DIVPRK”

Solves an initial-value problem for ordinary differential equations using the Runge-Kutta-Verner fifth-order and sixth order method.

Subprogram “DEVLGR”

The purpose of this subprogram is to compute all eigenvalues of a real matrix.

Sub program “DFTRF”

The purpose of this subprogram is to compute the Fourier coefficients of a real periodic sequence.

3-5. Input File “HBA.INP”

This file contains input data to the main program HBA. It includes the sets of data which are presented in Table 2.

Tab. 2. Input data for the computer software “HARM”

input to the software	description
omstart omend	rotor operating speed
omstep	
nr nq nk nt nst	linear and non linear freedoms
amp	system mass matrix
cpp	system damping matrix
akpp	system stiffness matrix
cons	constants in forcing functions
cost	cosine terms of forcing functions
sint	sine terms of forcing functions
vis c rad xl nsfd	squeeze film damper parameters
pl1 pl2	preload on damper freedoms
inikey	directive to initial guesses
seq	vector of initial guesses

Current version of program HBA, is based on dimensional parameters. Non-dimensional parameters may also be used. If so, it is the user's task to make necessary adjustments in the program. Since elements of mass, damping and stiffness matrices are initialized as zeros in program HBA, the user needs to fill in nonzero elements only. Constant terms in forcing functions assumed to correspond to gravity. For those

freedoms required, user supplies amount of masses only. They are multiplied by constant of gravity inside HBA. Cosine and sine terms of forcing functions assumed to rise from the presence of unbalance masses. Unbalance parameters given by the user is multiplied by ω^2 in program HBA, to provide unbalance forces. Squeeze film damper parameters including oil viscosity, radial clearance, radius, length, and number of squeeze film dampers should also be given as input data. Bearing parameter calculation is also included in the program HBA. Preload assumed to be effective on damper vertical freedoms, also affected by gravity. User enters amount of preloads without including gravity constant which is available in program HBA. Initial guesses are essential for harmonic balance solutions. This program can find its initial guessed solutions from two sources. If value for inikey is 01 then program fills in elements of vector 'seq' from those data available in input file 'HBA.INP'. If 'inikey' is not equal to 01 then program rewinds file 'ini.dat' and finds initial guesses from output of last program run.

3-6. Output File “HBA.OUT”

This file contains output data from program HBA. It includes information about the system under study such as total degrees of freedom, number of linear and nonlinear terms, level of sub-harmonics included, number of Fourier terms used and rotor frequency. Mass, damping and stiffness matrices plus damper specifications together with the amount of preloads on damper freedoms are also included. Displacement of damper inner and outer freedoms, corresponding absolute eccentricities, eccentricity of inner ring relative to outer ring and stability analysis data in form of eigenvalues are also part of output data.

4. Computer Software Verification**4-1. Flexible Rotor Bearing System – Centralized Damper**

Fig. 1 presents a flexible symmetric unbalanced rotor, the so-called Jeffcott rotor, supported on identical squeeze film dampers and centralizing springs of constant radial stiffness. The lumped mass at the bearing ends is m_2 , the centralizing spring has stiffness k_2 and the rotor stiffness between the central and either end node is k_1 . All unbalance is assumed to be at the disk, resulting in a disk mass eccentricity ρ_1 . Viscous damping at the disk is c_1 . Damping at the disk is negligible compared with that provided by the damper, and hence may be neglected. Since the rotor is symmetric about the disk, it suffices to consider one half of the system only. Thus, for cylindrical whirl, the motion of the system will be described by the plane motion in the damper of a journal of mass $m = m_1/2 + m_2$ with unbalance eccentricity $\rho = \rho_1 m_1 / (m_1 + 2m_2)$. Working frequency extends beyond the pin pin critical speed of the rotor ω_c , centralizing springs are retained and the rotor is centrally preloaded. Such a system results in synchronous circular orbit type solutions, and

has been analysed previously in the literature for both equilibrium solutions and their stability in the linear sense [12]. By virtue of the synchronous nature of the orbits, such stability analysis were possible without the need to resort to Floquet theory, by writing the perturbed equations of motion with respect to a rotating reference frame, thereby obtaining linear differential equations with constant coefficients. Once super and/or sub-harmonics of the excitation frequency are also present, as they will be in general, such a procedure no longer removes the periodicity of the coefficients in the perturbed equations of motion. Solutions for this flexible rotor model therefore proved particularly useful in evaluating the Floquet theory based stability analysis, since there are circular orbit solutions which are alleged to be unstable, and indeed, unexpectedly so [12]. Referring to Fig. 1 the equations of motion are given by:

$$\begin{aligned}
 m_1 \ddot{x}_1 + c_1 \dot{x}_1 + k_1(x_1 - x_3) &= \rho_1 m_1 \omega^2 \cos \alpha \\
 m_1 \ddot{x}_2 + c_1 \dot{x}_2 + k_1(x_2 - x_4) &= \rho_1 m_1 \omega^2 \sin \alpha \\
 m_2 \ddot{x}_3 + k_1(x_3 - x_1) + k_2 x_3 &= F_y \\
 m_2 \ddot{x}_4 + k_1(x_4 - x_2) + k_2 x_4 &= F_z
 \end{aligned}$$

where

$$y = x_3 \text{ and } z = x_4$$

The equations are in the form of Eq. (1) with $r = 4$ and $q = 2$. The following values of non-dimensional system parameters were used to allow comparison with [2];

$$\begin{aligned}
 M_1 &= 0.75, M_2 = 0.25, K_1 = 0.75/(\omega/\omega_c)^2 \\
 K_2 &= 0.25/(\omega/\omega_c)^2, C_1 = 0.0075/(\omega/\omega_c), \\
 U &= 0.3, \omega_r/\omega_c = 0.5.
 \end{aligned}$$

The equilibrium solutions for various values of the bearing parameter ω_b/ω_c are reported in [12]. Using the generalized theory that is developed and presented in this article, the same frequency response curve was obtained for $\omega_b/\omega_c = 0.3$ as indicated in Fig. 3.

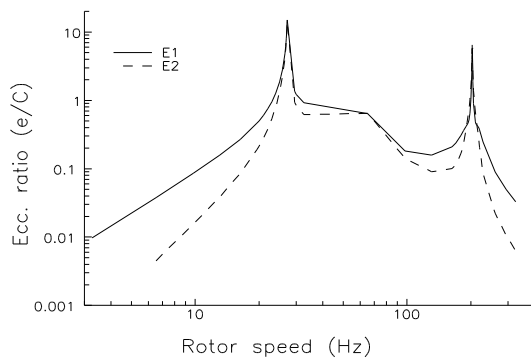

Fig. 3. Predicted frequency response of circular orbit eccentricities for the Jeffcott rotor, (E1 output from program HBA) (E2 equilibrium solutions reported in [12])

($U=0.3, M_2 = 0.25, \omega_r/\omega_c = 0.5, \omega_b/\omega_c = 0.3$)

4-2. Flexible Rotor Bearing System–Uncentralized Damper

The effect of removing the retainer springs from the fluid film bearings is simulated by changing the amount of stiffness corresponding to the damper degrees of freedom. Results are presented in Fig.4.

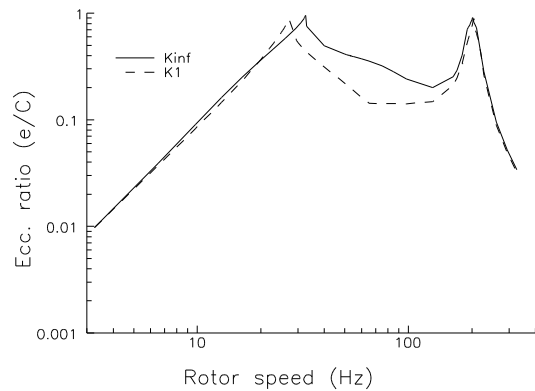

Fig. 4. Predicted frequency response for the Jeffcott rotor, (dashed for supported damper, blank line for unsupported damper) (U=0.3, M2 = 0.25, ωr/ωc = 0.5, ωb/ωc = 0.3)

Fig.4 presents a comparison between eccentricity ratios for the two cases of rotor bearings on nonlinear squeeze film bearing with and without spring support. While the rest of the rotor bearing data are the same as for the case of centralized damper in section 4.1. In this figure the dashed line is program HBA output for damper with spring support and the blank line is program output for damper without spring support. While program predictions for the second critical speed are the same for both cases, predictions of the 1st critical speed are different. For the amount of unbalance applied to the rotor at disk location, for Jeffcott rotor with unsupported fluid film bearing, the 1st critical speed is higher.

5. Conclusions

The ability to theoretically model rotors and simulate response aids both efficient design of new rotors and rapid troubleshooting of existing rotors. Rolling element bearings, fluid film bearings, seals, etc. are commonly used in rotating machinery. There have however been cases of rotors mounted in such elements exhibiting non-linear behaviour. Noncircular orbit type dampers, such as unsupported or un-centralized dampers, have generally necessitated transient solutions, which are computationally prohibitive for design studies of large order systems, particularly for systems with low damping. By utilizing harmonic balance with appropriate condensation, it is possible to considerably reduce the number of

simultaneous nonlinear equations inherent to this approach.

The harmonic balance approach for finding equilibrium solutions for general multi-degree of freedom rotor bearing systems with non-linear supports can result in a considerable reduction in the number of simultaneous non-linear equations which need to be solved iteratively.

Perturbation of the equilibrium solutions result in as many second order linear differential equations with periodic coefficients as there are degrees of freedom. Floquet theory may be conveniently applied to determine stability.

The theory of harmonic balances is successfully developed and is also used for the development of a computer software for the dynamic analysis of general multi-degree of freedom rotor bearing systems with nonlinear support elements.

The versatility of the technique is illustrated on systems with and without centralizing springs and of increasing complexity. Of particular interest, is the applicability of this approach to rotor bearings with unsupported fluid film bearings with relative large unidirectional loadings, i.e., at high orbit eccentricities as occurs when the damper has just lifted off, as well as to the confirmation of the instability.

References

- [1] Zhu, C.S., Robb, D.A., Ewins, D.J., "Analysis of the Multiple-Solution Response of a Flexible Rotor Supported on Non-Linear Squeeze Film Dampers", Journal of Sound and Vibration, Vol. 252, No. 3, 2002, pp. 389-408.
- [2] Rabinowitz, M.D., Hahn, E.J., "Experimental Evaluation of Squeeze Film Supported Flexible Rotors", ASME J. Eng. Pow, 105; 1983, pp. 495-503.
- [3] Nikolajsen, J.L., Holmes, R., "Investigation of Squeeze Film Isolators for the Vibration Control of a Flexible Rotor", Journal of Mechanical Eng. Science, 21; 1979, pp. 247-252.
- [4] San Andres, L.A., Vance, J.M., "Effect of Fluid Inertia on the Performance of Squeeze Film Damper Supported Rotors", ASME Journal of Eng Gas Turb, 1988, 110: pp. 51-57.
- [5] Zhao, J.Y., Linnett, I.W., McLean, L.J., "Stability and Bifurcation of Unbalanced Response of a Squeeze Film Damped Flexible Rotor", ASME Journal of Tribology, 116, 1994, pp. 361-368.
- [6] Ramesh, K., Kirk, R.G., "Non-Linear Response of rotors Supported on Squeeze Film Dampers", Proceedings of DETC99, 17th biennial ASME vibrations conference, Las Vegas, Nevada, USA, 1999, pp. 1-7.
- [7] Cookson, R.A., Kossa, S.S., "The Effectiveness of squeeze Film Damper Bearings Supporting Rigid Rotors Without a Centralizing Spring", International Journal of Mechanical Sciences, Vol. 21, 1982, pp. 639-650.
- [8] Rezvani, M.A., Hahn, E.J., "An Experimental Evaluation of Squeeze Film Dampers Without Centralizing Springs," Tribology Intl. Vol.29, No. 1, 1996, pp. 51-59.
- [9] Hahn, E.J., "An Energy Approach to Linearizing Squeeze-Film Damper Forces," Proceedings IMechE, Vol. 199, (C1), 1985, pp. 57-63.
- [10] Zhao, J., McLean, L.J., "Eccentric Operation of a Squeeze-Film Damper: Zero and Pie Film Damper model Predictions Compared," International Conference -Hydrodynamic Bearing Rotor Systems Dynamics, Xi'an, 7 p, 1990.
- [11] Shiau, T.N., Jean, A.N., "Predictions of Periodic Response of Flexible Mechanical Systems with Non-Linear Characteristics," ASME Journal of Vibration and Acoustics, Vol. 102, No. 4, 1990, pp. 501-507.
- [12] McLean, L.J., Hahn, E.J., "Unbalance Behaviour of Squeeze Film Damped Multi Mass Flexible Rotor Bearing Systems," Trans. ASME Journal of Lubrication Technology, Vol. 105, 1983, pp. 22-28.
- [13] Coddington, E.A., Levinson, N., "Theory of Ordinary Differential Equations", McGraw-Hill, New York, 1995.
- [14] Chang-Jian, Cai-Wan, Chen, Chao-Kuang, "Chaos and Bifurcation of a Flexible Rub-Impact Rotor Supported by oil Film Bearings with Nonlinear Suspension", Elsevier, Mechanism and Machine Theory, Vol. 42, 2007, pp. 312-333.
- [15] Rezvani, M.A., Hahn, E.J., "The Adequacy of the Short Bearing Approximation for Dynamically Loaded Narrow Hydrodynamic Bearings," ASME Journal of Tribology, Vol. 115, No. 3, 1993, pp. 544-549.
- [16] Stolarski, T.A., *Tribology in Machine Design*, Butterworth- Heinemann, 2000.

Nomenclature

- A_k $r \times 1$ vector of Fourier coefficients defined by Eqs. (3); $k = 0, \dots, n$
- B_k $r \times 1$ vector of Fourier coefficients defined by Eqs. (3); $k = 0, \dots, n$
- B angular velocity for non-dimensionalization
 $= \mu RL^3 / [(m_1 + 2m_2)\omega C^3]$
- q, \dots, c_n damping coefficients associated with rotor of freedom x_1, \dots, x_n
- C radial clearance of damper
- C $r \times r$ damping and gyroscopic matrix
- C_k $r \times 1$ vector of Fourier coefficients defined by Eq. (8); $k = 0, \dots, n$
- d diameter of rotor in Fig. 1.
- e, ε journal eccentricity; $\varepsilon = e/C$
- E equilibrium value
- F $r \times 1$ vector of forces as defined in Eq. (1)
- F_y, F_z fluid film force components in the y and z directions

h	fluid film thickness
I	$r \times r$ identity matrix
k	order of Fourier series component; $k = 0, 1, \dots, n$
k_1, k_2	stiffness of retainer springs and rotor segments in Fig. 1
K	$r \times r$ stiffness matrix
L	length of axial land of damper
m	$m_1 / 2 + m_2$
m_1	lumped mass of disk in Fig. 1
m_2	lumped mass of each of the bearings in Fig. 1
M	$r \times r$ mass matrix
n	highest harmonic of truncated Fourier series
N	integer, usually 1 or 2
O	$r \times r$ null matrix
O	$r \times 1$ null vector
p	degrees of freedom without nonlinear forces
P	preload for centralizing the damper
q	degrees of freedom involving nonlinear forces
Q, R	$r \times r$ matrices defined by Eqs. (12) and (13)
r	degrees of freedom of rotor bearing system
R	bearing radius in Fig. 1
S_k	$r \times 1$ vector of Fourier coefficients defined by Eq. (8); $k = 1, \dots, n$
t	time
T	$r \times r$ matrix defined by Eqs. (15) and (16)
U	unbalance parameter, $\rho_1 m_1 / [(m_1 + 2m_2)C] = \rho / C$
V, W	$r \times 1$ vectors defined by Eqs. (19) and (20) and (15) and (16) respectively
W	static load parameter = $g / (C\omega_b^2)$
x, y, z	coordinate system with x in direction of shaft rotation and origin located along line joining bearing centres
X	$r \times 1$ vector of the degrees of freedom
Z	axial coordinate measured from bearing centre O_b in x direction; $\bar{Z} = Z / L$
$\alpha, \alpha_1, \alpha_2$	location of disk unbalance eccentricities at time t in Fig. 1.
γ	a speed or frequency ratio; $\gamma = \omega / \omega_b$
λ_k	defined by Eq. (4)
μ	absolute viscosity of lubricant
ρ	$\rho_1 m_1 / (m_1 + 2m_2)$
ρ_1, ρ_2	unbalance eccentricities at lumped rotor mass in Fig. 1.
Ω	fundamental frequency of steady state response
ω	angular velocity of rotor