

EFFICIENCY OF IMPROVED HARMONY SEARCH ALGORITHM FOR SOLVING ENGINEERING OPTIMIZATION PROBLEMS

Serdar Carbas^{1,*} and Mehmet Polat Saka²

¹*Department of Engineering Sciences, Middle East Technical University, Ankara, Turkey*

²*Department of Civil Engineering, University of Bahrain, Isa Town, Bahrain*

ABSTRACT

Many optimization techniques have been proposed since the inception of engineering optimization in 1960s. Traditional mathematical modeling-based approaches are incompetent to solve the engineering optimization problems, as these problems have complex system that involves large number of design variables as well as equality or inequality constraints. In order to overcome the various difficulties encountered in obtaining the solution of these problems, new techniques called metaheuristic algorithms are suggested. These techniques are numerical optimization algorithms that are based on a natural phenomenon. In this study, a state-of-art improved harmony search method with a new adaptive error strategy is proposed to handle the design constraints. Number of numerical examples is presented to demonstrate the efficiency of the proposed algorithm in solving engineering optimization problems.

Received: 5 May 2012; Accepted: 10 January 2013

KEY WORDS: improved harmony search algorithm; metaheuristic techniques, optimization problems; engineering design

1. INTRODUCTION

The improvements in the performance of high-speed computing systems and the progress taken place in computational methods of optimization, the meta-heuristic techniques which are computationally intensive have become practical and used widely in obtaining the

* Corresponding author: S. Carbas, Department of Engineering Sciences, Middle East Technical University, Ankara, Turkey

† E-mail address: carbas@metu.edu.tr (s. carbas)

solution of engineering design optimization problems in recent years. These techniques simulate the paradigm of a biological, chemical or social system to develop a numerical optimizations method. Depending on what they simulate they are named accordingly such as evolutionary algorithms that mimic survival of the fittest, ant colony or particle swarm optimizations which are based on swarm intelligence or simulated annealing that imitates the cooling of molten metals through annealing [1-6]. It is generally accepted that stochastic approaches can handle engineering optimization problems more efficiently and easily than deterministic algorithms. In addition to their robustness with respect to the growth of problem size, other significant advantages of these methods are related to their relative simplicity and suitability for problems where the implementation of the optimization process is complicated by complexity and differentiability of design domain [7]. These heuristic algorithms are now becoming very popular in many disciplines of science and engineering [8-13].

In this study an improved harmony search optimum design algorithm is proposed for solving engineering design optimization problems. The classical harmony search method is improved by including some new strategies and then used to determine the solution of optimum design problem. The benchmark design examples taken from literature and the structural design examples are considered to demonstrate the effectiveness and robustness of the improvements suggested in the harmony search technique. The novelty of this study not only lies in the improvement suggested for the classical harmony search method, but also lies in the new error adaptive strategy suggested for constraint handling.

2. STATEMENT OF AN OPTIMIZATION PROBLEM

A general engineering optimization problem can be defined as follows [14];

Minimize;

$$f(X), X = \{X_1, X_2, \dots, X_{Nd}\} \quad (1)$$

which is subjected to

$$g_i(X) \leq 0, i = 1, 2, \dots, p \quad (2)$$

and

$$h_j(X) = 0, j = 1, 2, \dots, m \quad (3)$$

where

$$L X_k \leq X \leq U X_k, k = 1, 2, \dots, N_d \quad (4)$$

Here, $f(X)$ is the objective function, X denotes the decision solution vector, N_d is the number of decision variables, $L X_k$ and $U X_k$, are the lower and the upper bound of each decision variable, respectively. p is the number of inequality constraints and m is the number of equality constraints. One of the most difficult parts encountered in practical engineering design optimization is the constraint handling. Real-world limitations frequently introduce multiple, non-linear and non-trivial constraints on a design.

3. HARMONY SEARCH OPTIMIZATION (HSO)

This meta-heuristic method imitates the improvisation process of a musician seeking a pleasing harmony. Musician can play a note from existing memory or perform variations on an existing piece or create an entirely new piece. These actions represent the basic three operations of the harmony search method. A note can be played from pleasing songs stored in memory or a note can be played close in pitch to one that is in the memory or a note can be played totally randomly from the entire range of the instrument. Harmony search method follows the same logic. The algorithm consists of five steps that are given in the following. The detailed explanation of the method can be found in [15] which is summarized in the following.

Step 1. Initialization. Initialize the optimization operators of HS algorithm includes the harmony memory (hm), the harmony memory size (hms), the harmony memory considering rate ($hmcr$), and the pitch adjusting rate (par).

Step 2. Harmony memory matrix is initialized. Each row of harmony memory matrix contains the values of design variables which are randomly selected feasible solutions from the design pool for that particular design variable.

Step 3. New harmony memory matrix is improvised. Generate a new harmony vector from the hm , based on memory considerations, pitch adjustments, and randomization.

Step 4. Harmony Memory matrix is updated. If a new harmony vector is better than the worst harmony in the hm , judging in terms of the objective function value, the new harmony is included in the hm and the existing worst harmony is excluded from the hm .

Step 5. Termination. Repeat steps 2 and 3 until the terminating criterion is satisfied.

3.1 Improved Harmony Search Optimization (IHSO)

In classical harmony search method the parameters $hmcr$ and par are selected prior to the application of the method and they are kept constant until the end of the iterations. The numerical applications have shown that the selection of values for $hmcr$ and par is problem dependent and the initial values selected affect the performance of the algorithm. Hence, in order to determine the optimum solution it is necessary to solve the optimization problem several times with different values of these parameters and select the solution with minimum weight. It is apparent that such application devaluates the efficiency of the algorithm. In order to overcome this discrepancy, numbers of improvements are suggested in the literature [16-21]. In this study, different strategies are proposed for $hmcr$ and par [22]. par is updated using the concept suggested by Coelho and Bernert [23] as follows:

$$par(i) = par_{\min} + (par_{\max} - par_{\min}) \times degree(i) \quad (5)$$

where, $par(i)$ is the pitch adjusting rate for generation i , par_{\min} is the minimum adjusting rate, par_{\max} is the maximum adjusting rate, and i is the generation number. The $degree$ is updated according to the following expression:

$$degree(i) = \frac{(H\text{Cost}_{\max}(i) - H\text{Cost}_{\text{mean}})}{(H\text{Cost}_{\max}(i) - H\text{Cost}_{\min}(i))} \quad (6)$$

where, $H\text{Cost}_{\max}(i)$ and $H\text{Cost}_{\min}(i)$ are the maximum and minimum function objective values in generation i , respectively; $H\text{Cost}_{\text{mean}}$ is the mean of objective function value of the harmony memory. The improvisation of $hmcr$ is carried out using the newly-coined following expression;

$$hmcr(i) = hmcr_{\max} - (hmcr_{\max} - hmcr_{\min}) \cdot degree(i) \quad (7)$$

where, $hmcr(i)$ is the harmony memory considering rate for generation i , $hmcr_{\max}$ is the maximum considering rate, $hmcr_{\min}$ is the minimum considering rate, and i is the generation number.

3.2 Adaptive Constraint Handling

Once the new harmony vector is obtained using the above-mentioned rules, it is then checked whether it violates problem constraints. If the new harmony vector is severely infeasible, it is discarded. If it is slightly infeasible, it is included in the harmony memory matrix. In this way the violated harmony vector which may be infeasible slightly in one or more constraints is used as a base in the pitch adjustment operation to provide a new harmony vector that may be feasible[11]. This is carried out by using larger error value initially and then this value is adjusted during the design cycles according to the expression given below;

$$Tol(i) = Tol_{\max} - \frac{(Tol_{\max} - Tol_{\min}) \cdot \sqrt{i}}{\sqrt{iter_{\max}}} \quad (8)$$

where, $Tol(i)$ is the error value in iteration i , Tol_{\max} and Tol_{\min} are the maximum and the minimum error values defined in the algorithm respectively, $iter_{\max}$ is the maximum iteration number until which tolerance minimization procedure continues. Equation (8) provides larger error values in the beginning of the design cycles and quite small error values towards the final design cycles. Hence when the maximum design cycles are reached the acceptable design vectors remain in the harmony memory matrix and the ones which do not satisfy one or more design constraints smaller than the error tolerance would be pushed out during the design iterations.

4. NUMERICAL EXAMPLES

As numerical examples, three well-known benchmark optimization problems as well as optimum topology design of a latticed geodesic dome and a optimum design of a steel rigid frame are used to demonstrate the performance effectiveness of the IHSO algorithm. Here, the main control parameters, $hmcr$ and par , in IHSO algorithm are dynamically changed during optimization process by the use of Equations (5) and (7). The values of par_{max} and $hmcr_{max}$ are taken as 0.99 and the 0.01 is assigned to par_{min} and $hmcr_{min}$. The maximum number of searches is taken as 30000 in each design case. This number is determined after carrying out several designs with a larger number of iterations and it is noticed that the result obtained within the 30000 iterations remains the same even if the iterations continued further. The optimum solution located using the IHSO algorithm in each benchmark design example is compared to the previously reported results in the literature.

4.1 Himmelblau's Nonlinear Optimization Problem

The first problem, called Himmelblau's function [24], is a commonly used benchmark function for nonlinear constrained optimization problems. This problem is adopted to test the performance of proposed IHSO technique. Problem has five design variables and three constraints. Problem definition and optimum design results are as in the following;

Minimize;

$$f(x) = 5.358547x_3^2 + 0.8356891x_1x_5 + 37.293239x_1 - 40792.141 \quad (9)$$

which is subjected to

$$0 \leq g_1(x) \leq 92, \quad 90 \leq g_2(x) \leq 110, \quad 20 \leq g_3(x) \leq 25 \quad (10)$$

and side constraints are

$$78 \leq x_1 \leq 102, \quad 33 \leq x_2 \leq 45, \quad 27 \leq x_3 \leq 45, \quad 27 \leq x_4 \leq 45, \quad 27 \leq x_5 \leq 45 \quad (11)$$

where

$$\begin{aligned} g_1(x) &= 85.334407 + 0.0056858x_2x_5 + 0.0006262x_1x_4 - 0.0022053x_3x_5 \\ g_2(x) &= 80.51249 + 0.0071317x_2x_5 + 0.0029955x_1x_2 + 0.0021813x_3^2 \\ g_3(x) &= 9.300961 + 0.0047026x_3x_5 + 0.0012547x_1x_3 + 0.0019085x_3x_4 \end{aligned} \quad (12)$$

Himmelblau [24] first solved this problem by using the generalized reduced gradient (GRG) method. Then it is studied by Gen and Cheng [25] using genetic algorithms (GAs). Runarsson and Yao [26] proposed an evolutionary strategies (ES) algorithm with stochastic ranking for the solution of this problem. Wu et. al. [27] used the Particle Swarm Optimizer (PSO) in order to obtain the optimum solution of this problem. The classical Harmony Search Optimization (HSO) solution tabulated in Table 1 is as given by Lee and Geem [28]. The HSO algorithm-based method found a best solution vector of $x = (78.0000, 33.0000, 29.9950,$

45.0000, 36.7760) with a function value equal to $f(x) = -30665.50$. The optimal solution of the same problem is obtained as $x = (78.0000, 33.27773, 27.22356, 44.99983, 44.49837)$ with corresponding function value equal to $f(x) = -31011.87$ by the IHSO as shown in Table 1.

Table 1: Optimum results for Himmelblau's nonlinear optimization problem.

<i>Optimum solutions obtained by different methods</i>						
<i>Design variables</i>	<i>IHSO</i>	<i>PSO</i>	<i>HSO</i>	<i>ES</i>	<i>GRG</i>	<i>GAs</i>
x_1	78.0000	78.0000	78.0000	78.0000	78.6200	81.4900
x_2	33.27773	33.0000	33.0000	33.0000	33.4400	34.0900
x_3	27.22356	29.9952	29.9950	29.9953	31.0700	31.2400
x_4	44.99983	45.0000	45.0000	45.0000	44.1800	42.2000
x_5	44.49837	36.7758	36.7760	36.7758	35.2200	34.3700
$g_1(x)$	91.99505	92.0000	91.7147	92.0000	91.7927	91.7819
$g_2(x)$	100.46506	98.8405	98.8405	98.8405	98.8929	99.3188
$g_3(x)$	20.00000	20.0000	19.9999	20.0000	20.1316	20.0604
$f(x)$	-31011.87	-30665.39	-30665.50	-30665.54	-30373.95	-30183.58

4.2 Welded Beam Design

A rectangular beam, designed as a cantilever beam, is selected as second numerical example. The geometric view and the dimensions of the beam are illustrated in Figure. 1 The beam is designed to carry a certain load with minimum overall cost of fabrication. The optimization problem has four design variables; $h=x_1$: the thickness of the weld, $l=x_2$: the length of the welded joints, $t=x_3$: the width of the beam, $b=x_4$: the thickness of the beam [29].

Minimize;

$$f(x) = 1.10471x_1^2 x_2 + 0.04811x_3 x_4 (14.0 + x_2) \quad (13)$$

which is subjected to

$$g_1(x) = \tau(x) - \tau_{\max} \leq 0 \text{ as shear stress} \quad (14)$$

$$g_2(x) = \sigma(x) - \sigma_{\max} \leq 0 \text{ as bending stress in the beam,} \quad (15)$$

$$\begin{aligned} g_3(x) &= x_1 - x_4 \leq 0, \\ g_4(x) &= 0.10471x_1^2 + 0.04811x_3 x_4 (14.0 + x_2) - 5 \leq 0, \\ g_5(x) &= 0.125 - x_1 \leq 0 \text{ as side constraints,} \end{aligned} \quad (16)$$

$$g_6(x) = \delta(x) - \delta_{\max} \leq 0 \text{ as end deflection of the beam,} \tag{17}$$

$$g_7(x) = P - P_c(x) \leq 0 \text{ as buckling load on the bar} \tag{18}$$

and also, design variables of the problems are limited as;

$$0.1 \leq x_1 \leq 2.0, \quad 0.1 \leq x_2 \leq 10, \quad 0.1 \leq x_3 \leq 10, \quad 0.1 \leq x_4 \leq 2.0 \tag{19}$$

where

$$\tau' = \frac{P}{\sqrt{2}x_1x_2}, \tau'' = \frac{MR}{J}, M = P(L + \frac{x_2}{2}), R = \sqrt{\frac{x_2^2}{4} + (\frac{x_1 + x_3}{2})^2},$$

$$J = 2 \left\{ x_1x_2\sqrt{2} \left[\frac{x_2^2}{12} + (\frac{x_1 + x_3}{2})^2 \right] \right\},$$

$$\delta(x) = \frac{4PL^3}{Ex_3^3x_4}, \sigma(x) = \frac{6PL}{x_4x_3^2}, P_c(x) = \frac{4.013E\sqrt{\frac{(x_3^2x_4^6)}{36}}}{L^2} \left(1 - \frac{x_3}{2L}\sqrt{\frac{E}{4G}} \right)$$

$P = 6000 \text{ lb}, \quad L = 14 \text{ in.}, \quad E = 30 \times 10^6 \text{ psi}, \quad G = 12 \times 10^6 \text{ psi}$
 $\tau_{\max} = 13600 \text{ psi}, \quad \sigma_{\max} = 30000 \text{ psi}, \quad \delta_{\max} = 0.25 \text{ in.}$

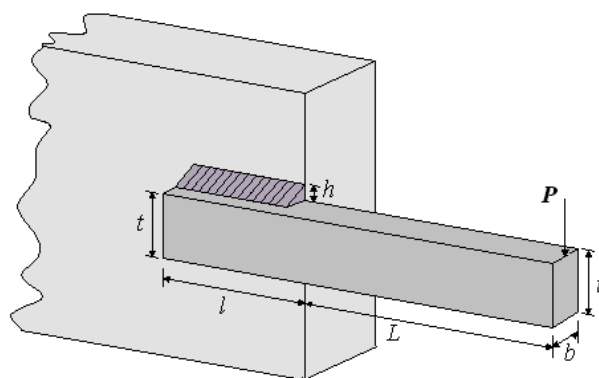

Figure 1. Welded beam structure.

The same problem was also solved by Gandomi et. al. [30] using a Firely Algorithm (FA). Deb [31] used a simple genetic algorithm (GAs) with traditional penalty function to solve the same problem. Coello [32] solved this problem by using a self-adaptive penalty approach (SAPA). The optimum solutions obtained using classical HSO and PSO are taken from references [27] and [28], respectively. The optimum solutions and comparison of results for this problem are tabulated in Table 2.

Table 2: Optimum results for welded beam design.

<i>Optimum solutions obtained by different methods</i>						
<i>Design variables</i>	<i>IHSO</i>	<i>FA</i>	<i>SAPA</i>	<i>HSO</i>	<i>PSO</i>	<i>GAs</i>
$x_1 (h)$	0.203907	0.2015	0.20880	0.24420	0.244369	0.2489
$x_2 (l)$	3.499898	3.5620	3.42050	6.22310	6.217519	6.1730
$x_3 (t)$	9.063898	9.0414	8.99750	8.29150	8.291471	8.1789
$x_4 (b)$	0.205594	0.2057	0.21000	0.24430	0.244369	0.2533
$f(x)$	1.729664	1.73121	1.74830	2.38075	2.38075	2.4331

4.3 Pressure Vessel Design

The optimum design of the cylindrical pressure vessel capped at both ends by hemispherical heads shown in Figure. 2 is considered as the third numerical example [33]. This problem has four design variables, such as; T_s (thickness of the shell, x_1), T_h (thickness of the head, x_2), R (inner radius, x_3) and L (length of cylindrical section of the vessel, not including the head, x_4). T_s and T_h are integer multiples of 0.0625 inch, which are the available thickness of rolled steel plates, and R and L are continuous.

Minimize

$$f(x) = 0.6224x_1x_3x_4 + 1.7781x_2x_3^2 + 3.1661x_1^2x_4 + 19.84x_1^2x_3 \quad (20)$$

which is subjected to

$$g_1(x) = -x_1 + 0.0193x_3 \leq 0 \quad (21)$$

$$g_2(x) = -x_2 + 0.00954x_3 \leq 0 \quad (22)$$

$$g_3(x) = -\pi x_3^2 x_4 - \frac{4}{3} \pi x_3^3 + 1296000 \leq 0 \quad (23)$$

$$g_4(x) = x_4 + 240 \leq 0 \quad (24)$$

where the design variables have to be in the following ranges

$$0.0625 \leq x_1 \leq 6.1875, 0.0625 \leq x_2 \leq 6.1875, 10 \leq x_3 \leq 200, 10 \leq x_4 \leq 200 \quad (25)$$

This problem solved by Coello and Montes [34] by using genetic algorithms (GAs) with a dominance-based tournament selection scheme (GADTS) to handle constraints. Deb [35] investigated same problem previously by using Geneas. It has also been dealt by Cao and Wu [36] by using a mixed variable evolutionary programming (MVEP). A PSO solution is given in [27]. All the optimum solutions attained by different algorithms are tabulated in

Table 3.

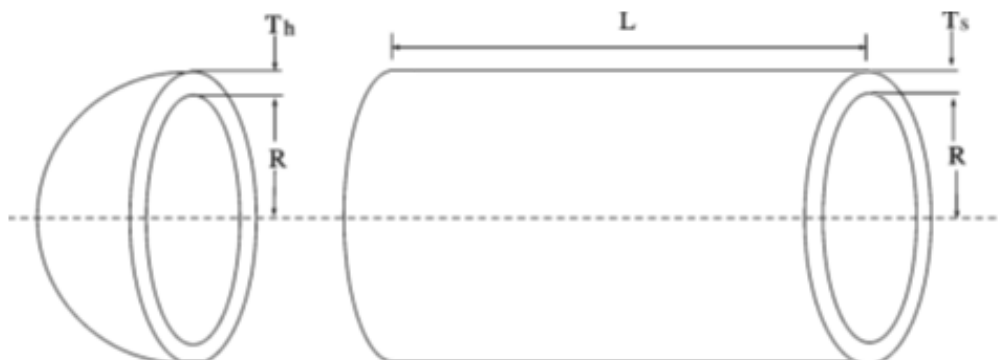

Figure 2. Pressure vessel design.

Table 3: Optimum results for pressure vessel design.

<i>Optimum solutions obtained by different methods</i>					
<i>Design variables</i>	<i>IHSO</i>	<i>PSO</i>	<i>GADTS</i>	<i>Geneas</i>	<i>MVEP</i>
$x_1 (T_s)$	0.8125	0.8125	0.8125	0.9345	1.0000
$x_2 (T_h)$	0.4375	0.4375	0.4375	0.5000	0.6250
$x_3 (R)$	42.0991013	42.0984456	40.097398	48.3290	51.1958
$x_4 (L)$	176.6285002	176.6365956	176.654405	112.6790	90.7821
$g1 (x)$	0.0000012	0.0000000	-0.000020	-0.004750	-0.0119
$g2 (x)$	-0.0358746	-0.0358808	-0.035891	-0.038941	-0.1366
$g3 (x)$	-0.1647335	0.0000000	-27.886075	-3652.87684	-13584.5631
$g4 (x)$	-63.3714998	-63.3634042	-63.345953	-127.321000	-149.2179
$f(x)$	6059.63511	6059.71430	6059.94634	6410.38110	7108.61600

4.4 Latticed Geodesic Dome Design

The improved harmony search algorithm is used to determine the optimum topology of a single layer geodesic dome as shown in Figure 3. In this type of dome, it is possible to generate the structural data for the geometry if three parameters are known. These parameters are the diameter of the dome, the total number of rings, and the height of the crown. Once the values of these parameters are decided, the total number of members, member incidences, total number of joints, and joint coordinates of the dome can be obtained automatically [22].

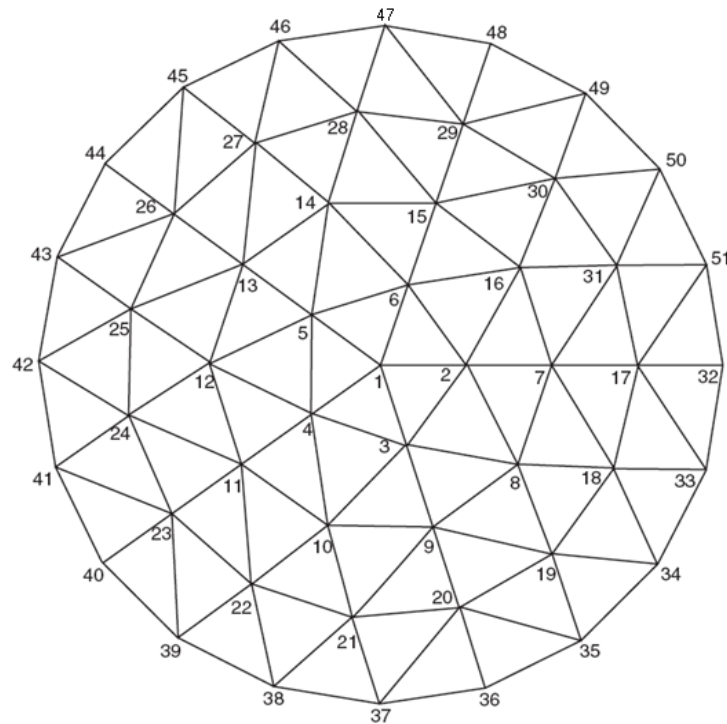

Figure 3. Plan view of a geodesic dome.

The design pool for the total number of rings for this dome contains 3 values that are 3, 4, and 5. For the crown height, a list is prepared starting from 1m to 8.75 m with the increment of 0.25 m. There are 32 values altogether for the harmony search algorithm to choose from. Among the steel tubular sections given in LRFD-AISC [37], 37 steel tubular sections are selected as the standard list. The sectional designations selected vary from PIPST13 to PIPDEST203 where abbreviations ST, EST, and DEST stands for standard weight, extra strong, and double-extra strong respectively. The yield strength is taken as 250 MPa. The modulus of elasticity for the steel is taken as 205 kN/mm². The diameter of the dome is taken as 20 m. The limitations imposed on the joint displacements are given in Table 4. It is apparent from the table that both upper and lower bound limitations on the restricted joint displacements are assumed as the same value. However it should be noticed that while the upper bound values are applied to those joint displacements which are on the negative direction of global Y-axis, the lower bound values are applied to the joint displacements that may be on the positive direction of the same global axis. Geodesic dome is subjected to 25 kN of concentrated loads which are applied on each joint of the dome. The sandwich type aluminum cladding is used. The load of this cladding (including frame elements to be used for the girts) is taken as 200 N/m². Dead load is converted into equivalent point load for each joint for the sake of simplicity. For this conversion distributed load is multiplied by projected area of the dome and then this result is divided by joint number of the dome which gives the load acting on each joint. The loading of the dome is shown in Figure 4.

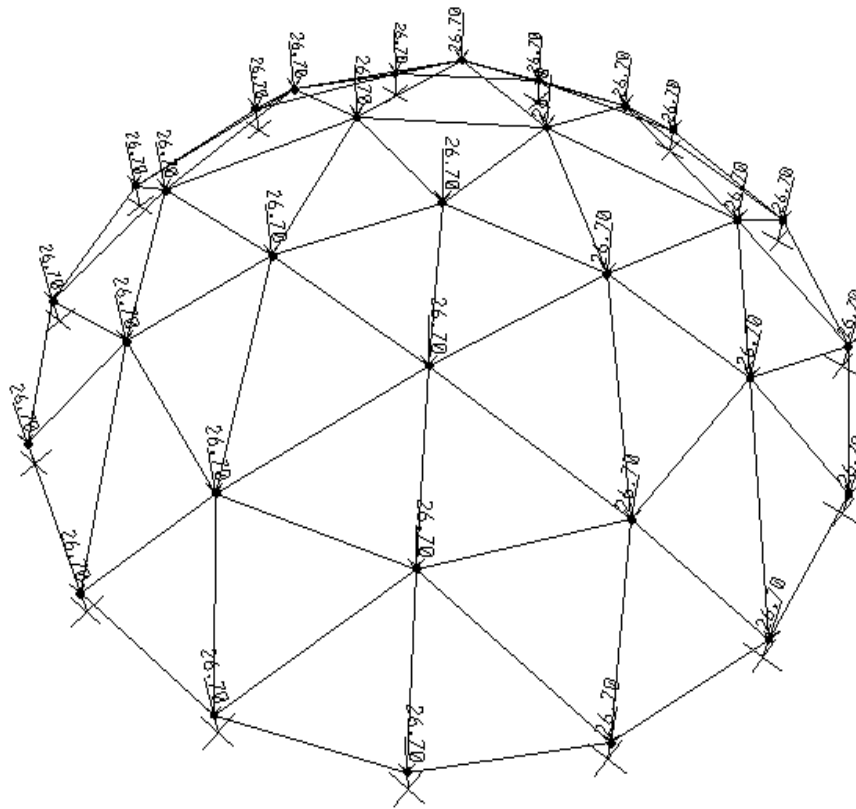

Figure 4. Loading of geodesic dome.

Table 4: Displacement restrictions of a single layer geodesic dome.

Joint number	Displacement limitations (mm)					
	X-direction		Y-direction		Z-direction	
	Upperbound	Lowerbound	Upperbound	Lowerbound	Upperbound	Lowerbound
1	-	-	-	-	28	-28
2	33	-33	33	-33	28	-28
3	33	-33	33	-33	28	-28

The optimum steel tubular designations for each member group obtained by the classical and the improved HS algorithms, the height of the dome and the maximum values of restricted displacements for both algorithms are given in Table 5. The optimum geodesic dome obtained by both the classical and improved HS algorithm has 3 rings. They have the minimum weights of 2124.2 kg and 2089.1 kg respectively. The maximum values of restricted displacements of geodesic dome obtained by the improved and classical HS algorithms are -2.76 mm and -2.41 mm. Under the equipment loading, the improved harmony search technique for geodesic dome has provided 1.68% lighter optimum design than those of classical one. It is noticed that the strength limitations are dominant in the design problem. In the optimum dome the strength ratios are very close to 1.

Table 5: Optimum designs for single layer geodesic dome with classical and improved harmony search algorithms for unsymmetrical loading.

Algorithm Used		Classical Harmony Search Algorithm	Improved Harmony Search Algorithm
Optimum number of rings		3	3
Optimum height of crown (m)		5.25	4.50
Optimum tubular section designations	Group1	PIPST 64	PIPST 64
	Group2	PIPST 51	PIPST 51
	Group3	PIPST 64	PIPST 64
	Group4	PIPST 32	PIPST 38
	Group5	PIPST 64	PIPST 64
	Group6	PIPST 13	PIPST 13
Maximum displacement (mm)		-2.41	-2.76
Maximum strength ratio		0.90	0.99
Weight (kg)		2124.2	2089.1

4.5 Rigid Steel Frame Design

The four-storey, three-bay rigid steel frame shown in Figure 5 is designed as a last numerical example. The dimensions of the frame and the loadings are shown in the figure. The frame is subjected to gravity loading of 2.0 kN/m on the beams of roof level and 2.4 kN/m on the beams of each floor. The lateral loading of 15 kN is applied to each floor. The modulus of elasticity is 200 kN/mm². The frame consists of 28 members that are collected in 6 groups. The beams of roof and intermediate floors are considered to be two different groups as shown in the figure.

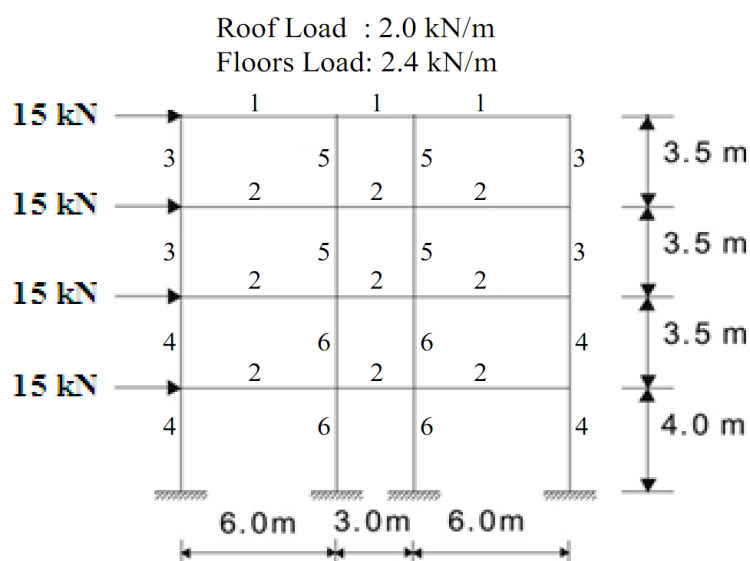

Figure 5. Four-storey, three-bay frame

Table 6: Optimum designs for four-storey, three-bay rigid steel frame.

Group No	Member Type	Classical Harmony Search Algorithm	Improved Harmony Search Algorithm
1	Beam	W150X13.5	W200X15
2	Beam	W310X23.8	W310X21
3	Column	W250X17.9	W250X17.9
4	Column	W310X21	W200X15
5	Column	W310X21	W310X21
6	Column	W310X28.3	W360X32.9
Weight (kg)		2556.74	2434.38

Also the outer and the inner columns of the frame are considered to be two different groups in each two storey. The allowable inter-storey drift is taken into account as height of a column/300 in each storey which is equal to 1.17 cm while the lateral displacement of the top storey is limited to total height of the frame/300 which is equal to 4.84 cm. The strength capacities of steel members are computed according to LRFD-AISC [37]. The wide-flange (W) profile list consisting of 272 ready sections is used to size column and beam members. Besides, the column to column and the beam to column compatibilities of the frame members are checked during the optimum design process.

The optimum steel section designations obtained by both improved harmony search and classical harmony search methods are given in Table 6. The improved harmony search algorithm yields the minimum weight of the frame as 2434.38 kg. The same frame is also designed using the classical harmony search algorithm under the same loading conditions and the optimum design achieved in that study is 2556.74 kg. The design obtained by the classical harmony search algorithm is 5.03% heavier than the one obtained by the improved harmony search algorithm.

5. CONCLUSIONS

In this study, the Improved Harmony Search Optimization (IHSO) algorithm with new adaptive error approach of constraint handling is proposed which can be used in obtaining optimum solution of engineering design optimization problems. The improved HS algorithm does not need initialization of harmony search parameters. The values of control parameters for harmony memory considering rate (hmcr) and pitch-adjusting rate (par) are automatically adjusted by the proposed algorithm during optimization cycles. It is important to note that the initial values selected have a significant effect on the optimum solution obtained and their value change depending on the optimization problem considered. In the classical harmony search algorithm the values of these parameters remain unchanged during the iterations. The algorithm developed is used to find the optimum solutions of

Himmelblau's nonlinear optimization problem, a welded beam design, design optimization of a pressure vessel as well as optimum topology design of a latticed geodesic dome and the optimum design of a rigid steel frame. The optimum results obtained for benchmark problems are compared to those previously reported in the literature. The results reveal that proposed IHSO algorithm not only decreases the computational cost, but also determines the best optimum among all the other techniques considered in this study. It is also shown that the new adaptive error strategy approach for constraint handling is reliable and efficient. It is obvious from results that the combination of new strategies for harmony search algorithm and constraint handling creates a robust and versatile tool for obtaining the optimum solutions of engineering design optimization problems.

REFERENCES

1. Paton R. *Computing with Biological Metaphors*, Chapman & Hall, USA, 1994.
2. Adami C. *An Introduction to Artificial Life*, Springer-Verlag, New York, 1998.
3. Kennedy J, Eberhart R, Shi Y. *Swarm Intelligence*, Morgan Kaufmann Publishers, USA, 2001.
4. Kochenberger GA, Glover F. *Handbook of Metaheuristics*, Kluwer Academic Publishers, Netherlands, 2003.
5. De Castro LN, Von Zuben FJ. *Recent Developments in Biologically Inspired Computing*, Idea Group Publishing, USA, 2005.
6. Dreoj J, Petrowski A, Siarry P, Taillard E. *Metaheuristics for Hard Optimization*, Springer-Verlag, Berlin, Heidelberg, 2006.
7. Zhigljavsky A, Zilinskas A. *Stochastic Global Optimization*, Springer, USA, 2008.
8. Hasançebi O, Carbas S, Dogan E, Erdal F, Saka MP. Performance evaluation of metaheuristic search techniques in the optimum design of real size pin jointed structures, *Comput Struct*, 2009; **87**(5-6): 284-302.
9. Hasançebi O, Carbas S, Dogan E, Erdal F, Saka MP. Comparison of nondeterministic search techniques in the optimum design of real size steel frames, *Comput Struct*, 2010; **88**(17-18): 1033-48.
10. Hasançebi O, Carbas S, Saka MP. Improving the performance of simulated annealing in structural optimization, *Struct Multidiscip Optim*, 2010; **41**(2): 189-203.
11. Saka MP, Aydogdu I, Hasancebi O, Geem ZW. Harmony Search Algorithms In Structural Engineering, in: Yang X-S and Koziel S. (Eds.), Chapter 6, Computational Optimization and Applications in Engineering and Industry, Springer-Verlag, Berlin, Heidelberg, 2011, pp. 145-182.
12. Kaveh A, Talatahari S. Optimization of large-scale truss structures using modified charged system search, *Int J Optim Civil Eng*, 2011; **1**(1): 15-28.
13. Kaveh A, Zolghadr A. An improved charge system search for structural damage identification in beams and frames using changes in natural frequencies, *Int J Optim Civil Eng*, 2012; **2**(3): 321-39.
14. Hasançebi O, Carbas S. Ant colony search method in practical structural optimization, *Int J Optim Civil Eng*, 2011; **1**(1): 91-105.

15. Lee KS, Geem ZW. A new structural optimization method based on the harmony search algorithm, *Comput Struct*, 2004; **87**(5-6): 284-302.
16. Mahdavi M, Fesanghary M, Damangir E. An improved harmony search algorithm for solving optimization problems, *Appl Math Comput*, 2007; **188**(2): 1567-79.
17. Taherinejad N. Highly reliable harmony search algorithm, European Conference on Circuit Theory and Design (ECCTD'09), Antalya, Turkey, August 23-27, 2009, pp. 818-822.
18. Omran MGH, Mahdavi M. Global-best harmony search, *Appl Math Comput*, 2008; **198**(2): 643-56.
19. Geem ZW. Particle-swarm harmony search for water network design, *Eng Optim*, 2009; **41**(4): 297-311.
20. Geem ZW, Roper WE. Various continuous harmony search algorithms for web-based hydrologic parameter optimization, *Mathematical Modelling and Numerical Optimisation*, 2010; **1**(3): 231-26.
21. Hasançebi O, Erdal F, Saka MP. An adaptive harmony search method for structural optimization, *J Struct Eng*, ASCE, 2010; **136**(4): 419-31.
22. Carbas S, Saka MP. Optimum topology design of various geometrically nonlinear latticed domes using improved harmony search method, *Struct Multidiscip Optim*, 2012; **45**(3): 377-99.
23. Coelho LS, Bernert DLA. An improved harmony search algorithm for synchronization of discrete-time chaotic systems Chaos, *Solitons and Fractals*, 2009; **41**(5): 2526-32.
24. Himmelblau DM. *Applied Nonlinear Programming*, Mc-Graw Hill, Daryaganj, New Delhi, India, 1972.
25. Gen M, Cheng R. *Genetic Algorithms and Engineering Design*, John Wiley and Sons, NY, USA, 1997.
26. Runarsson TP, Yao X. Stochastic ranking for constrained evolutionary optimization, *IEEE Trans Evol Comput*, 2000; **4**: 284-94.
27. He S, Prempain E, Wu QH. An improved particle swarm optimizer for mechanical design optimization problems, *Eng Optim*, 2007; **36**(5): 585-605.
28. Lee KS, Geem ZW. A new meta-heuristic algorithm for continuous engineering optimization-harmony search theory and practice, *Comput Meth Appl Mech Eng*, 2005; **194**(36-38): 3902-33.
29. Rao SS. *Engineering Optimization: Theory and Practice*, John Wiley and Sons, 3rd edition, 1996.
30. Gandomi AH, Yang XS, Alavi AH. Mixed variable structural optimization using firefly algorithm, *Comput Struct*, 2011, **89**(23-24): 2325-36.
31. Deb K. Optimal design of a welded beam via genetic algorithms, *AIAA J*, 1991; **29**: 2013-5.
32. Coello CAC. Use of a self-adaptive penalty approach for engineering optimization problems, *Computers In Industry*, 2000; **41**(2): 113-27.
33. Sandgren E. Nonlinear integer and discrete programming in mechanical design optimization, *J Mech Des*, 1990; **112**: 223-9.
34. Coello CAC, Montes EM. *Use of dominance-based tournament selection to handle constraints in genetic algorithms*, *Intelligent Engineering Systems through Artificial*

- Neural Networks* (ANNIE'2001), ASME Press, St. Louis, Missouri, 2001, pp. 177–182.
35. Deb K. *Geneas: a robust optimal design technique for mechanical component design*, *Evolutionary Algorithms in Engineering Applications*, in: Dasgupta D. and Michalewicz Z. (Eds.), Springer-Verlag, Berlin, Heidelberg, 1997, pp. 497–514.
 36. Cao YJ, Wu QH. A mixed variable evolutionary programming for optimisation of mechanical design, *Eng Intell Syst Electr Eng Comm*, 1999; **7**(2): 77–82.
 37. *Manual of Steel Construction Load and Resistance factor design*, Structural Members, Specifications & Codes, American Institute of Steel Construction Inc., 1991.