

## **NOVEL EVEN HARMONIC MIXER FOR 3 G MOBILE RECEIVERS**

**S. Shamsinejad, M. Soleimani, M. Tayarani, and N. Komjani**

Electrical Engineering Department  
Iran University of Science and Technology (IUST)  
Tehran, Iran

**Abstract**—This paper reports a high IIP3 even harmonic mixer with a new circuit configuration. This mixer employs an antiparallel diode pair, open and short circuited stubs and a radial stub as filters to separate RF input signal, Baseband output signal and LO Power. This mixer is used for down converting 3 G Mobile downlink Signal at 2140 MHz to BaseBand by using a local oscillator at 1070 MHz in direct conversion configuration. This mixer must comply with the requirements specified by 3G UMTS: 3rd order Input Intercept Point = 14.466 dBm  $\geq$  11 dBm, Noise Figure = 9 dB and Conversion Loss = 11 dB.

### **1. INTRODUCTION**

Mixers play an important role in the design of microwave circuits and they have various applications. Direct conversion receivers are very common in the recent configurations specially 3 G mobiles, therefore, signal must be down converted from 2140 MHz to baseband with 60 MHz bandwidth. So far, quite a lot of mixer structures with direct conversion ability have been proposed, almost all of which have been based on active mixers with lumped elements configuration. In some structures which use passive mixers for mixing procedure, balanced configuration with 4 diodes is preferred due to Higher IIP3 [1], and SPD mixers just leave for very high frequency about 40 GHz because these mixers have some important features such as: even harmonic mixing that uses local oscillator at half frequency and also suppressing additional undesirable harmonics and using two diodes instead of four that causes cheaper circuit, etc. [2, 3].

In this paper we report a Subharmonically Pumped Diode Mixer (SPD) that employs an Anti Parallel Diode Pair (APDP) for direct conversion mixing procedure [4]. This type of mixers inherently suffers from low IIP3 characteristics at low frequency. We solve this problem by adding a radial stub and additional open circuited stubs in suitable positions. We suppress additional fourth order harmonic by open circuited stubs and extremely decrease effects of the baseband part on the RF input by radial stub techniques because RF and baseband ports are connected to the same node in SPD mixers [2].

## 2. CIRCUIT CONFIGURATION OF NOVEL EVEN HARMONIC MIXER

Figure 1 shows a circuit configuration of the even harmonic mixer. It consists of an antiparallel diode pair, an open and a short circuited stub with length of  $\lambda/4$  at LO frequency (half of the RF frequency), two open circuited stubs with length of  $\lambda/4$  at  $4 \times \text{LO}$  frequency (double RF frequency), baseband filter and radial stub. To suppress the virtual LO leakage of which frequency  $2n f_{\text{LO}}$  ( $n = 1, 2, \dots$ ) is close to that of RF signal, the mixer employs an antiparallel diode pair [4] as a mixing element.

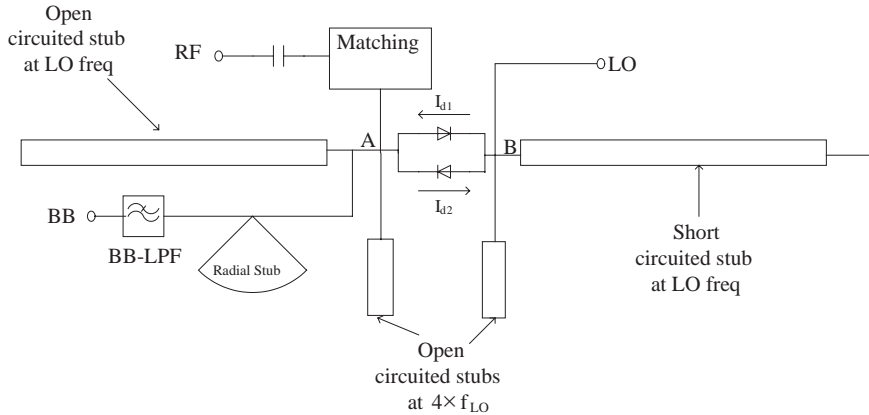

**Figure 1.** The circuit configuration of novel even harmonic mixer.

The LO currents  $I_{d1}$ ,  $I_{d2}$  through both diodes are with the same amplitude and in the opposite phase. Thus there are no components of even harmonics of the LO current ( $I_{d1} + I_{d2}$ ) [5]. As a result, the virtual LO ( $2n \cdot f_{\text{LO}}$ ) leakage is suppressed. RF input frequency  $f_{\text{RF}}$  is expressed as  $f_{\text{RF}} = 2n \cdot f_{\text{LO}}$  in direct conversion mixers. To achieve a

higher conversion efficiency, the mixer has been designed to be second harmonic one as  $n = 1$ .

Under the frequency relationship, the configurations of filters which separate RF input signal, baseband output signal and LO power are simplified by using the stubs as shown in Figure 1. The length of the open and the short circuited stubs is designed to be equal to an electrical length of  $\lambda/4$  at LO frequency  $f_{LO}$ . So the impedance of the open circuited stub seen from point A and the short circuited stub seen from point B in Figure 1 become zero and infinity, respectively. Thus, at point A the diodes are grounded by the open circuited stub, and the leakages of LO power at other ports are suppressed.

At RF input frequency  $f_{RF}$ , the impedances of the open circuited stub seen from point A and the short circuited stub seen from point B become infinity and zero, respectively. Thus, at point B, the diodes are grounded by the short circuited stub. By the stub the leakage of RF and LO power at other ports are suppressed.

Moreover, at baseband output frequency  $f_{BB}$ , the length of these stubs is negligibly small compared to the wavelength. Thus, at point B, the diodes are grounded by the short circuited stub [1, 2].

We added two open circuited stubs in points A and B with length equal to  $\lambda/4$  at  $4 \times f_{LO}$  for harmonic suppression at this frequency. The RF port impedance of the mixer including these stubs must be matched to  $50\Omega$  at RF frequency by the matching circuit.

Furthermore, we connected one radial stub with radius of  $\lambda_{RF}/4$  together with a  $\lambda_{RF}/4$  long transmission line to point A; so the baseband part seen from point A is open circuited at  $f_{RF}$ . By this method, we suppress the baseband effects on the RF input.

Lowpass baseband filter is a 6th order elliptic filter with cutoff frequency equal to 2 MHz because of 3G requirements [6–8].

### 3. DESIGN AND ANALYSIS

We implemented corresponding layout on RO3210 substrate which has dielectric constant as approximately 10.2 and used HSMS2862 as antiparallel diode pair [9]. After tuning, we achieved 8.409 mm and  $66^\circ$  as radius and angle of the radial stub, respectively. Large scale layout of this mixer is shown in Figure 2.

This circuit can be compressed by converting long stubs to bend form. Moreover, small open circuited stub at point A near the RF input must be repositioned and rotated 135 degrees in order to suppress its effects on the RF transmission line. We optimized the mentioned parts to equalize their  $S$  parameter matrices to that of the previous versions. The large scale layout of the final novel mixer is shown in Figure 3.

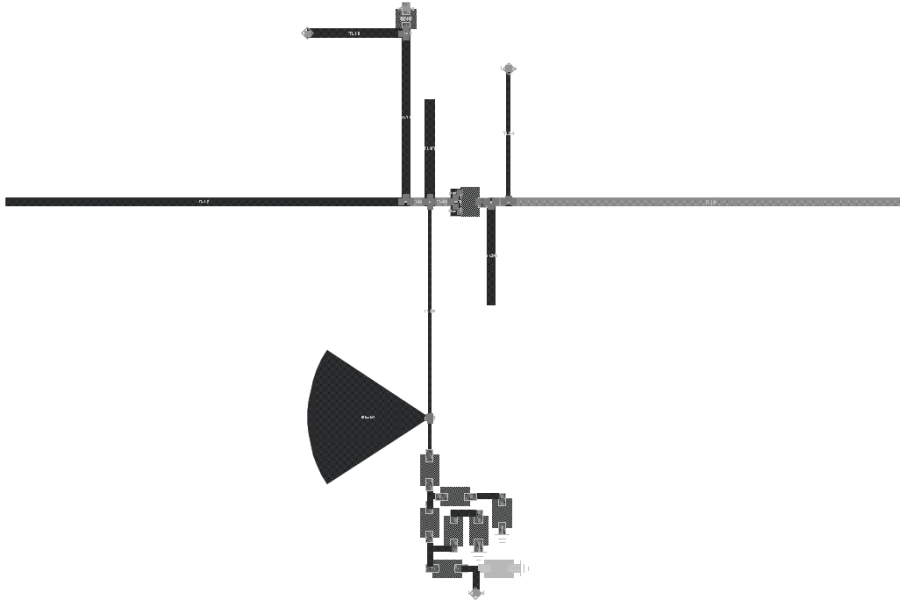

**Figure 2.** Layout of preliminary novel even harmonic direct conversion mixer before compacting.

The part number and the capacitance of coupling capacitor used in the RF port are as follows:

Part No: C17CG5R6B4T 5.6 pF

Table 1 shows dimensions of the different parts and Table 2 shows values of baseband LPF elements [8].

We analyzed this circuit by combining Harmonic Balance and momentum using ADS software and calculated 3rd order Input Intercept Point, Noise Figure, Conversion Loss and ports reflection coefficients represented in Table 3. We calculated the IIP3 for two  $-40$  dBm signals with 10 MHz and 20 MHz offset from center frequency of 2140 MHz, the same as 3 G standard test case [7, 10].

The resulted Frequency response of the baseband filter after analyzing by ADS is shown in Figure 5. As it can be seen, the filter separate the desired channel and fulfils the adjacent channel selectivity requirement (being greater than 33 dB) for the mixer of 3 G mobile receivers [6, 7].

We connected the filter to the interconnection of the radial stub and the  $\lambda_{RF}/4$  transmission line so that it doesn't affect the RF port due to the high impedance input of the  $\lambda_{RF}/4$  transmission line at

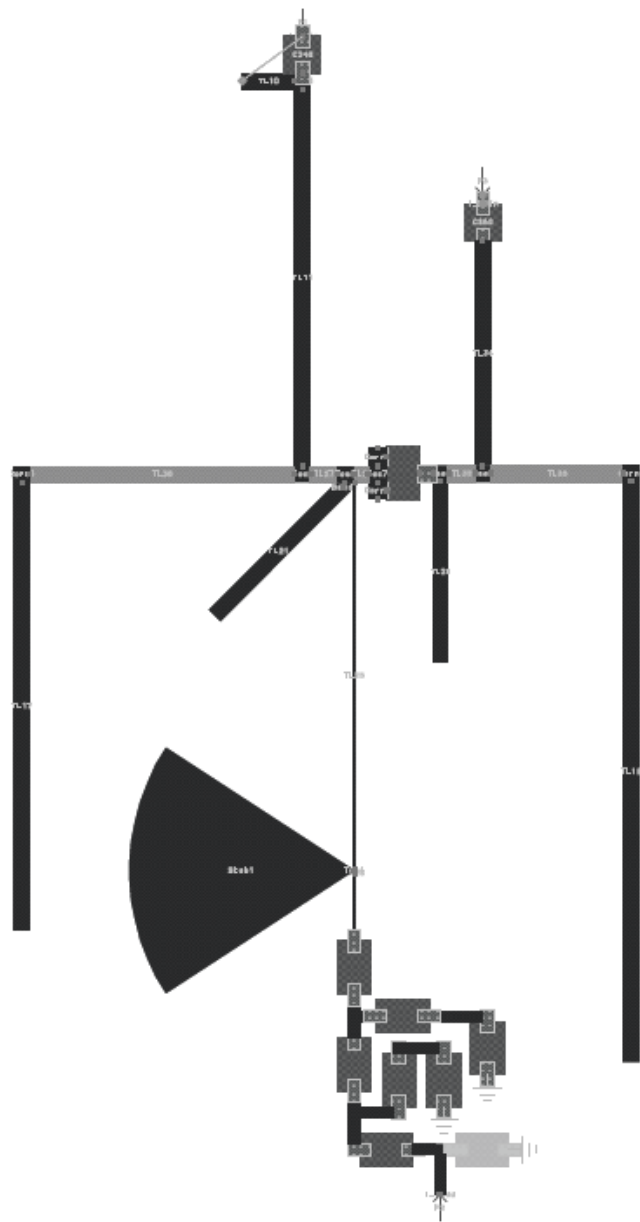

**Figure 3.** Layout of final novel even harmonic direct conversion mixer.

RF frequency seen from point A. AutoCAD layout of the mixer at its actual size is depicted in Figure 6.

**Table 1.** Dimensions of mixer parts.

parts	Dimension
Long stubs with length $\lambda/4$ at $f_{LO}$ (Local Oscillator frequency)	27.476 mm
Short stubs with length $\lambda/4$ at $4 \times f_{LO}$ (that is equal to $2 \times f_{RF}$ )	6.816 mm
Series transmission line in RF matching circuit	11.141 mm
Open circuited stub in RF matching circuit	6.529 mm
Radial stub radius*	8.409 mm
Radial stub angle*	66 degree
Line between radial stub and point A approximately with length $\lambda/4$ at $f_{RF}$	14.597 mm
Transmission lines width	0.592 mm

These values achieved after tuning procedure in order to high impedance input of the radial stub plus the  $\lambda/4$  transmission line at RF frequency.

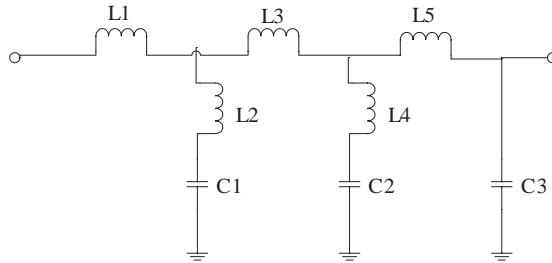

**Figure 4.** Baseband lowpass Elliptic filter.

**Table 2.** Elements values of Lowpass Elliptic filter.

Elements	Value	Manufacturer and part number
L1	4.7 uH	ATC MIC0805-4R7J
L2	1.8 uH	ATC MIC0805-1R8J
L3	4.7 uH	ATC MIC0805-4R7J
L4	3.3 uH	ATC MIC0805-3R3J
L5	3.9 uH	ATC MIC0805-3R9J
C1	1.5 nF	KMT C0805C152J1R
C2	1.2 nF	KMT C0805C122J1R
C3	2.7 nF	KMT C0805C272J1R

**Table 3.** Mixer analyzing results using momentum and harmonic balance by ADS software.

IIP3 (dBm)	NF (dB)	CL (dB)	Gama at RF port (dB)	Gama at LO port (dB)
14.466	9.017	10.948	-17.369	-18.048

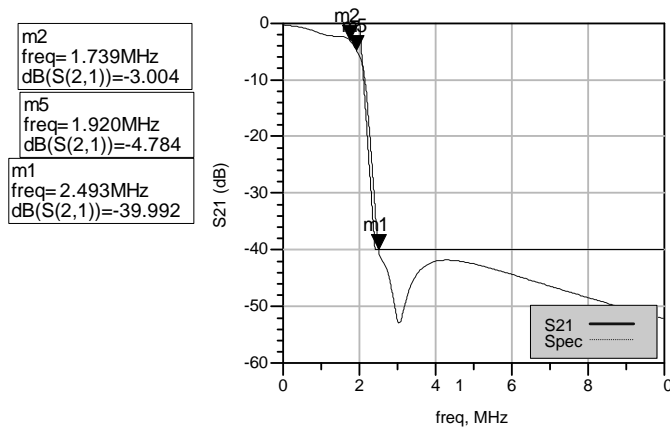

**Figure 5.** The baseband filter frequency response.

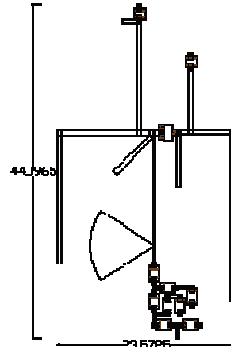

**Figure 6.** Actual size layout of novel compact even harmonic mixer.

#### 4. NOVEL EVEN HARMONIC MIXER APPLICATION IN 3G UMTS MOBILE RECEIVERS

3G mobile receivers are usually based on the direct conversion configuration which means that the RF input signal must be converted to baseband in one step [11]. Therefore, the local oscillator has the same center frequency as the RF signal (2140 MHz) with 60 MHz bandwidth (2110 MHz–2170 MHz) [7]. Direct conversion structures have some problems with undesired harmonics and the LO leakage. They are eliminated using novel mixer because its local oscillator frequency is half of the RF input frequency (1070 MHz). 3G systems have 12 channels each one with 5 MHz bandwidth and 3.84 Mcps chip rate. Therefore, the LO frequency is shifted from 1056.25 MHz to 1083.75 MHz by 2.5 MHz steps to cover all channels [7].

The mixer requires a local oscillator with 3 dBm power. Therefore, low power characteristic is another important feature of novel even harmonic mixer that makes its configuration suitable for 3G direct conversion receivers together with the other components.

#### 5. CONCLUSION

A 2140 MHz even harmonic mixer has been developed. IIP3 of 14.5 dBm, Noise Figure of 9 dB and Conversion Loss of 11 dB have been achieved. This mixer is based on direct conversion structure and requires a local oscillator at 1070 MHz with 3 dBm power.



## ACKNOWLEDGMENT

The authors wish to acknowledge the assistance and support of the IUST and ITRC.

## REFERENCES

1. Maas, S. A., *Microwave Mixers*, Artech House, 1993.
2. Itoh, K., A. Iida, Y. Sasaki, and S. Urasaki, "A 40 GHz band monolithic even harmonic mixer with an antiparallel diode pair," *IEEE MTT-S Digest*, 1991.
3. Matrecci, J. and F. K. David, "Unbiased, subharmonic mixer for millimeter wave spectrum analyzers," *1983 IEEE MTT-S International Microwave Symposium Digest*, 130–132, 1983.
4. Cohn, M., J. E. Degenford, and B. A. Newman, "Harmonic mixing with antiparallel diode pair," *IEEE Trans. On Microwave Theory Tech.*, Vol. 23, Vol. 8, 667–673, Aug. 1975.
5. Maas, S. A., *Nonlinear Microwave and RF Circuits*, Artech House, second edition, 2003.
6. Jensen, O. K., et al., "RF receiver requirements for 3G W-CDMA mobile equipment," *Microwave Journal*, Vol. 43, No. 2, 22–46, 2000.
7. Third Generation Partnership Project (3GPP), "UE radio transmission and reception (FDD)," *Technical Specification 25.101*, Vol. 3.0.0, October 1999.
8. Hong, J. S. and M. J. Lancaster, *Microstrip Filters for RF/Microwave Applications*, John Wiley & Sons Inc., 2001.
9. Agilent Technologies, *Agilent HSMS-286X Series Surface Mount Microwave Schottky Detector Diodes*, datasheet.
10. Mass, S., "Two-tone intermodulation in diode mixers," *IEEE Trans. Microwave Theory and Tech.*, Vol. 35, No. 3, 307–314, March 1987.
11. Itoh, K., M. Shimozawat, N. Suematsut, and O. Ishidat, "Even harmonic type direct conversion receiver ICS for mobile handsets: Design challenges and solutions," *IEEE Radio Frequency Integrated Circuits Symposium*, 1999.